

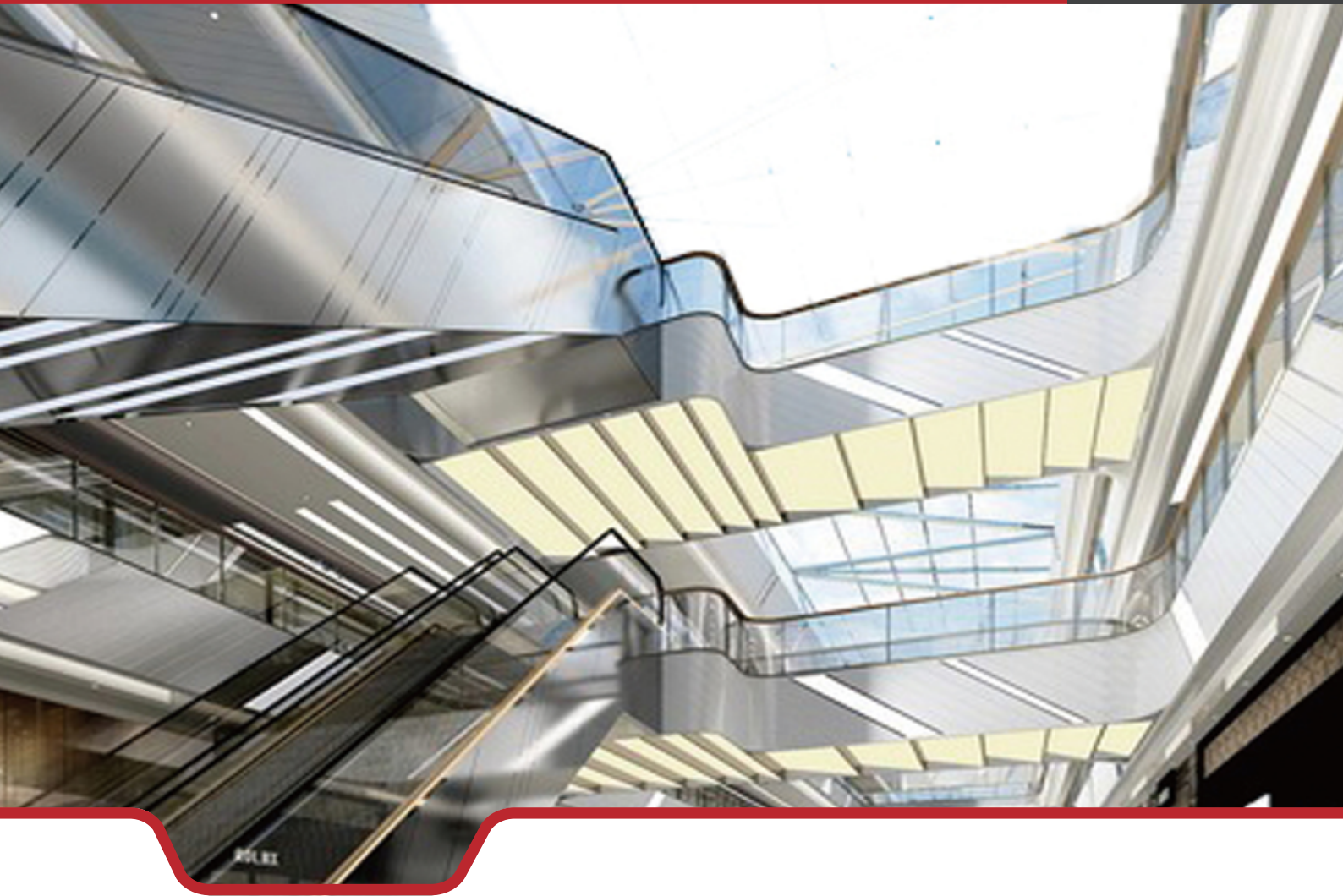

# IPC322E-IR-F36(60) 2MP Vandal-resistant Network IR Fixed Dome Camera



## Features:

- 1/2.8" progressive scan CMOS, 2MP
- True D/N(ICR), 3D-DNR
- IP66, IK10
- DC/PoE,  $\pm 25\%$  wide voltage range
- Smart IR

# IPC322E-IR-F36(60)

## 2MP Vandal-resistant Network IR Fixed Dome Camera

Camera	IPC322E-IR-F36	IPC322E-IR-F60
Sensor	1/2.8", 2 megapixel, progressive scan CMOS	
Shutter	Auto/manual, 1/6~1/8000 s	
Lens	3.6mm	6mm
Angle of View (H)	87.4°	53.2°
Day/Night	IR-cut filter with auto switch (ICR)	
Min. Illumination	Color: 0.06lux (F1.6, 50IRE), black & white: 0.03lux (F1.6, 50IRE)	
S/N	>52dB	
Image Rotation	Supported	
<b>Video</b>		
Maximum Resolution	1920 × 1080	
Video Compression	H.264, MJPEG	
Frame Rate	1080P (1920*1080) 30fps; 720P (1280*720) 30fps; D1 (720*576) 25fps	
Video Streaming	Triple	
<b>Audio</b>		
Audio Compression	G.711	
Two-way Audio	Supported	
<b>Network</b>		
Protocols	L2TP,IPv4,IGMP,ICMP,ARP,TCP,UDP,DHCP,PPPoE,RTP,RTSP,Qos,NTP,FTP,HTTP,SNMP,SIP	
Compatible Integration	ONVIF, IMOS,API	
<b>Interface</b>		
Audio I/O	Input: impedance 35kΩ; amplitude 2V [p-p] Output: impedance 600Ω; amplitude 2V [p-p]	
Alarm I/O	1 / 1	
Network	10M/100M Base-TX Ethernet	
<b>General</b>		
Power	12V DC, or PoE (IEEE802.3 af) Power consumption: 3.5W (5.5W with IR on)	
Dimensions (Ø x H)	Ø109 x 81 mm (Ø4.3" x 3.2")	
Weight	0.45 kg (0.99 lb)	
Working Environment	-30°C ~ +60°C (-22°F ~ 140°F), humidity ≤90% RH(non-condensing)	
Vandal Resistant	IK10	
Ingress Protection	IP66	

\*Product specifications and availability are subject to change without notice.

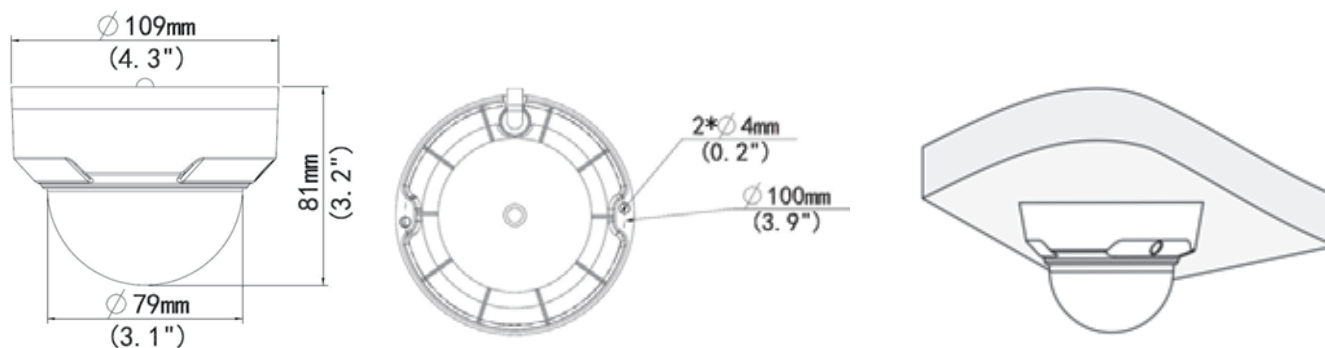

Zhejiang Uniview Technologies Co., Ltd.  
Address: Building No.10, Wanlun Science Park, Jiangling Road 88, Binjiang District, Hangzhou, P. R. China, 310051  
Website: [www.uniview.com](http://www.uniview.com) Email: [overseasbusiness@uniview.com](mailto:overseasbusiness@uniview.com)  
©2015 Zhejiang Uniview Technologies Co., Ltd. All rights reserved.

2015.08 OM-20150821-OWN V3.0